



## EXTRA WIDE AND DEEP SERIES **D3555KS Walk-In Tub**

The American Tubs' **D3555KS** from our The extra wide interior is specially designed to accommodate individuals up to 400 lbs. a safe and comfortable bathing experience. The D3555KS is by far the widest and most spacious walk-in tub model on the market.

The convenient, 23½", curved doorway makes entering and exiting the tub incredibly easy, while the extra-wide, 28¾" seat, with an under-seat support frame, provides ample bathing space with some additional "wiggle room". Attention should be paid to both the current size of the hot water heater as well as to the hallways, doorways and stairwells leading up to the bathroom. Having the largest well space of any of the American Tubs walk-in tubs, the D3555KS is a popular choice for multi-generational homes or for individuals who prefer showers.



### Therapeutic System Options

- Hydromassage System – 10 Jet
- Air Massage System – 20 Jet
- MicroBubble Skin-Cleansing System
- Vibro Jet Massage System (Wet/Dry)

### Door/ Drain Orientation

- Left Hand or Right Hand



### Available Colors

- White or Biscuit



### Standard Features

- Marine-Grade Fiberglass & Resin Composite Tub Shell
- High-Gloss, Triple-Coated Gelcoat Finish
- One-Piece, Stainless Steel Support Frame
- 6 Adjustable Leveling Legs
- Low, 6" Door Threshold
- Ergonomic Curved Door Handle
- Water-Tight Door Seal
- 17" High, ADA-Compliant, Contoured Seat
- Interior Safety Grab Bar
- Non-Slip Textured Floor
- Integrated Door Drain
- 2 Integrated Front Access Maintenance Panels
- Color-Matched Extension Kit to fill 60"
- Flangeless Design

### Contact Us Address

1101 Fullerton Rd.  
City Of Industry, CA 91748

### Phone

Tel: 626-581-3588  
Fax: 800-943-8652

### Web

[www.americantubs.com](http://www.americantubs.com)  
[sales@americantubs.com](mailto:sales@americantubs.com)

# Top View **D3555KS Walk-In Tub** Side View

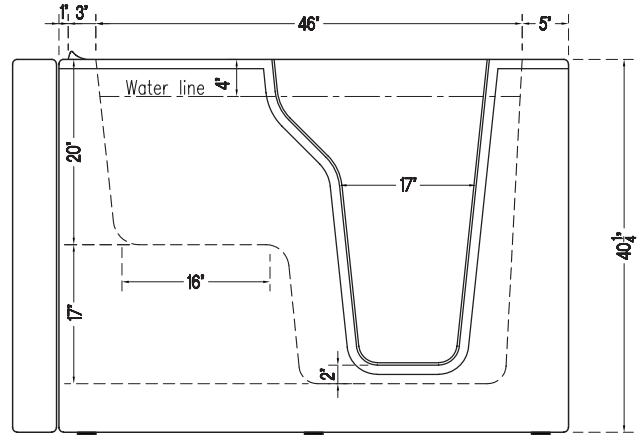
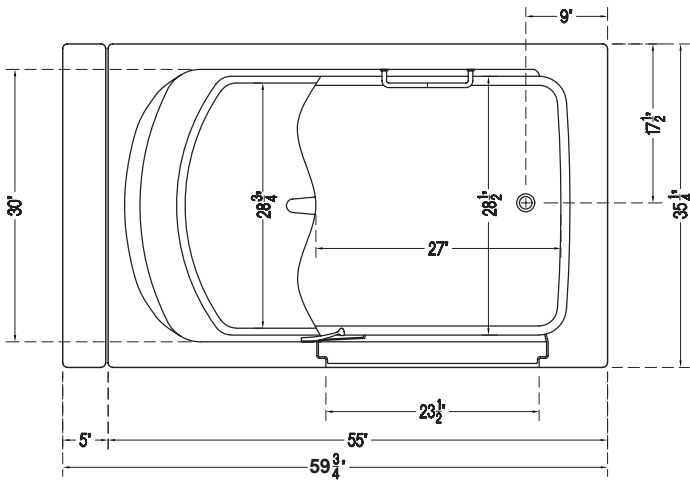

## D3555KS SPECIFICATIONS

Tub Dimensions	35 $\frac{1}{4}$ " W x 55" L x 40 $\frac{1}{4}$ " H
Top Diagonal	65"
Tub Weight	200 lbs.
Crated Dimensions	37" W x 56" L x 51" H
Water Capacity (with user inside approximately)	300 lb. / 72 Gallons 350 lb. / 67 Gallons 400 lb. / 62 Gallons
Seat Dimensions	H: 17"; W: 28 $\frac{3}{4}$ "
Door Width	23 $\frac{1}{2}$ " (At Top)
Door Swing	Inward-Swinging

## DRAIN OPTIONS

2" Hurry Drain™
Secondary Emergency Drain
Power Drain

## FAUCET OPTIONS

Elite	4 pcs	Chrome	Modern
Bellevue	5 pcs	Chrome	Modern
Bellevue	5 pcs	Satin Nickel	Modern
Bellevue	5 pcs	Oil-Rubbed Bronze	Modern

## Add-Ons And Upgrads

- Hydro Massage System
- Air Massage System
- Vibro Jet Massage System
- Microbubbles System
- Legs Only Massage System
- Chromotherapy Light System
- Aromatherapy System
- Ozone Sanitization System
- In-Line and Friction Heaters
- Additional Hip or Knee Jets
- Bidet Jet System

## Optional Accessories

- Heated Seat and Backrest
- Swing Glass Shower Door
- Swinging/Sliding Shower Door
- 4 Panel Folding Shower Screen
- L-Shaped and Straight Shower Rod Kits
- Rain Shower Faucet Package
- Adjustable Handheld Shower Holder
- Tile Flange Kit
- End Panel for the Seat and/or Faucet Side
- Neck Rest Pillow and Seat Cushion
- Bathing Support Harness
- U Safety Grab Bar



Microbubble Skin Therapy System

Heated Seat



Plumbing Safety Certified



Electrical Safety Certified



Limited Lifetime Warranty



Expedited Freight Shipping (less than 2 weeks)



## American Tubs

1101 Fullerton Rd. City Of Industry, CA 91748

Tel: 626-581-3588 Fax: 800-943-8652

[www.americantubs.com](http://www.americantubs.com) [sales@americantubs.com](mailto:sales@americantubs.com)