



COMPACT SERIES

D3138KW Walk-In Tub

The American Tubs' **D3138KW** from our Compact Series, with its uniquely compact design, affectionately called the "Cube Tub", can be installed where other traditional walk-in tubs cannot. The D3138KW's versatility makes it a perfect solution as a free-standing tub or for a three-quarter bath with an existing 36"x36" shower stall. This compact model comes equipped with 2 integrated side panels and an outward-swinging door which allows for a variety of creative installations, such as in laundry areas, washrooms, and garages. Unlike our other larger tub models, the D3138KW comes standard with a Kingston one-piece faucet set and attached handheld sprayer that mounts on its compact tub deck.

The adjustable shower slide bar and custom-tailored shower curtain are the most common accessories paired with the D3138KW to maintain the showering function of the space. When installing the D3138KW in a 3-wall alcove, it is important to install an additional maintenance hatch(es) for easy future access to system components.



Therapeutic System Options

- Hydromassage System – 10 Jet
- Air Massage System – 20 Jet
- MicroBubble Skin-Cleansing System
- Vibro Jet Massage System (Wet/Dry)

Door/Drain Orientation

- Left Hand or Right Hand



Available Colors

- White or Biscuit



Standard Features

- Marine-Grade Fiberglass & Resin Composite Tub Shell
- High-Gloss, Triple-Coated Gelcoat Finish
- One-Piece, Stainless Steel Support Frame
- 6 Adjustable Leveling Legs
- Low, 6" Door Threshold
- Ergonomic Curved Door Handle
- Water-Tight Door Seal
- 17" High, ADA-Compliant, Contoured Seat
- Interior Safety Grab Bar
- Non-Slip Textured Floor
- Integrated Door Drain
- 2 Integrated Front Access Maintenance Panels
- Flangeless Design

Contact Us Address

1101 Fullerton Rd.
City Of Industry, CA 91748

Phone

Tel: 626-581-3588
Fax: 800-943-8652

Web

www.americantubs.com
sales@americantubs.com

D3138KW Walk-In Tub

Top View

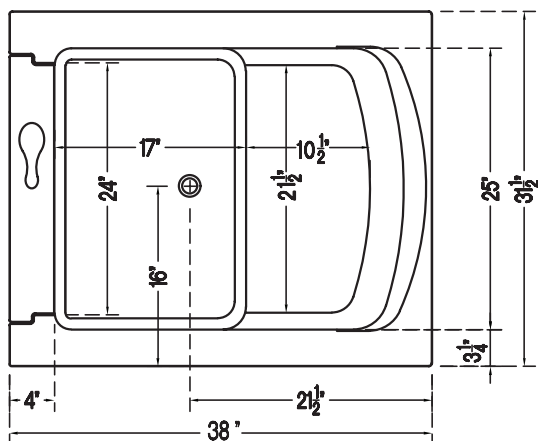

Side View

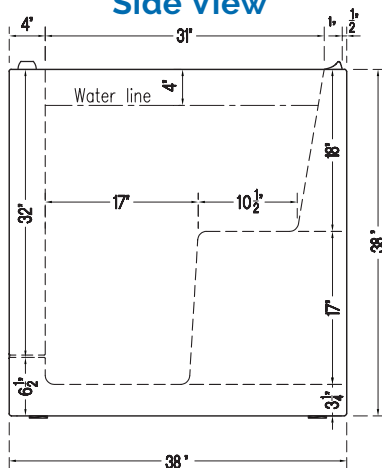

Front View

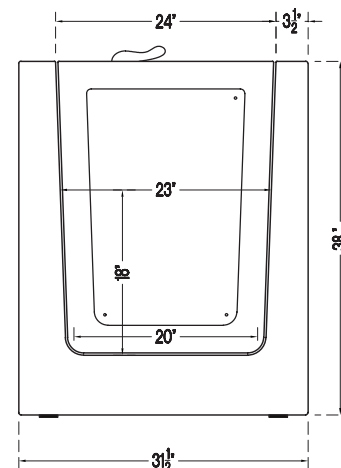

D3138KW SPECIFICATIONS

Tub Dimensions	31½" W x 38" L x 38" H
Top Diagonal	49¼"
Tub Weight	175 lbs.
Crated Dimensions	34" W x 40" L x 48" H
Water Capacity	120 lb. / 46 Gallons (with user inside approximately) 200 lb. / 42 Gallons 250 lb. / 39 Gallons
Seat Dimensions	H: 17"; W: 21½"
Door Width	24" (At Top)
Door Swing	Outward-Swinging

DRAIN OPTIONS

2" Hurry Drain™
Power Drain

FAUCET

Kingston 1 pc Chrome Compact

Add-Ons And Upgrades Optional Accessories

- Hydro Massage System
- Air Massage System
- Vibro Jet Massage System
- Microbubbles System
- Legs Only Massage System
- Chromotherapy Light System
- Aromatherapy System
- Ozone Sanitization System
- In-Line and Friction Heaters
- Additional Hip or Knee Jets
- Heated Seat and Backrest
- L-Shaped and Straight Shower Rod Kits
- Adjustable Handheld Shower Holder
- Neck Rest Pillow and Seat Cushion
- Bathing Support Harness
- U Safety Grab Bar



Heated Seat

Microbubble
Skin Therapy System



Plumbing Safety
Certified



Electrical Safety
Certified



Limited Lifetime
Warranty



Expedited Freight Shipping
(less than 2 weeks)



American Tubs

1101 Fullerton Rd. City Of Industry, CA 91748
Tel: 626-581-3588 Fax: 800-943-8652

www.americantubs.com sales@americantubs.com