



WHEELCHAIR SERIES

D3252KW Walk-In Tub

The American Tubs' **D3252KW** from our Wheelchair Series is extremely roomy, luxury-sized, and packed with specialty features.

The extra-wide 34 ½", outward-swinging door is the highlight of this slide-in or transfer seat walk-in tub design. The full seat access from the exterior of the tub was specifically engineered for wheelchair users, seniors with limited mobility, paraplegics, amputees, and those individuals with special needs.

The D3252KW comes highly recommended by in-home and long-term healthcare professionals. Special attention was paid to the door and locking mechanism to ensure a worry-free, leak-proof door seal.

The D3252KW is also an excellent choice for individuals up to 350 lbs. that may have difficulty fitting through smaller tub doorways.



Therapeutic System Options

- Hydromassage System – 10 Jet
- Air Massage System – 20 Jet
- MicroBubble Skin-Cleansing System
- Vibro Jet Massage System (Wet/Dry)

Door/Drain Orientation

- Left Hand or Right Hand



Available Colors

- White or Biscuit



Standard Features

- Marine-Grade Fiberglass & Resin Composite Tub Shell
- High-Gloss, Triple-Coated Gelcoat Finish
- One-Piece, Stainless Steel Support Frame
- 6 Adjustable Leveling Legs
- Low, 7" Door Threshold
- Ergonomic Curved Door Handle
- Water-Tight Door Seal
- 17" High, ADA-Compliant, Contoured Seat
- Interior Safety Grab Bar
- Non-Slip Textured Floor
- Integrated Door Drain
- 2 Integrated Front Access Maintenance Panels
- Color-Matched Extension Kit to fill 60"
- Flangeless Design

Contact Us Address

1101 Fullerton Rd.
City Of Industry, CA 91748

Phone

Tel: 626-581-3588
Fax: 800-943-8652

Web

www.americantubs.com
sales@americantubs.com

Top View **D3252KW Walk-In Tub** Side View

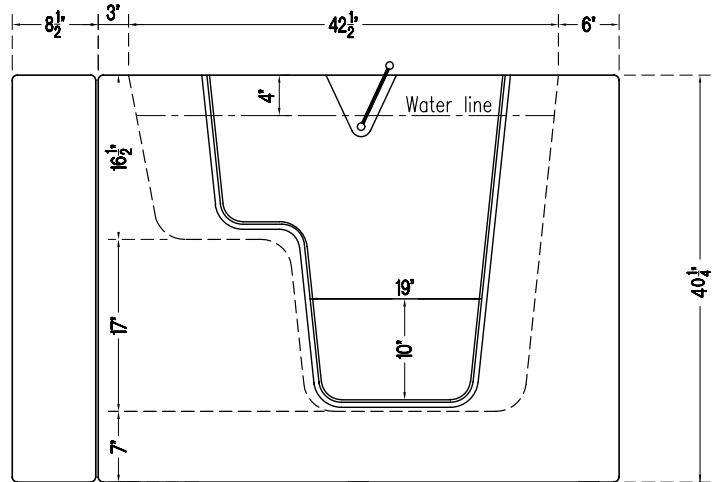
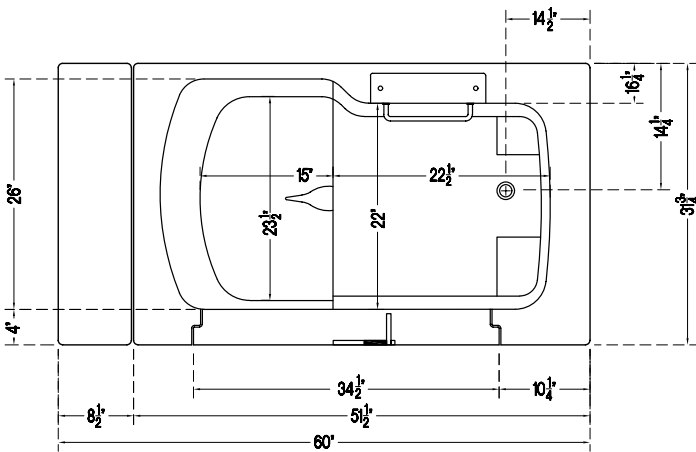

D3252KW SPECIFICATIONS

Tub Dimensions	31¾" W x 51½" L x 40¼" H
Top Diagonal	60½"
Tub Weight	195 lbs.
Crated Dimensions	35" W x 54" L x 49" H
Water Capacity	120 lb. / 70 Gallons
(with user inside approximately)	200 lb. / 65 Gallons
	250 lb. / 60 Gallons
Seat Dimensions	H: 17"; W: 23½"
Door Width	34½" (At top)
Door Swing	Outward-Swinging

DRAIN OPTIONS

2" Hurry Drain™
Secondary Emergency Drain
Power Drain

FAUCET OPTIONS

Elite	4 pcs	Chrome	Modern
Bellevue	5 pcs	Chrome	Modern
Bellevue	5 pcs	Satin Nickel	Modern
Bellevue	5 pcs	Oil-Rubbed Bronze	Modern

Add-Ons And Upgrades Optional Accessories

- Hydro Massage System
- Air Massage System
- Vibro Jet Massage System
- Microbubbles System
- Legs Only Massage System
- Chromotherapy Light System
- Aromatherapy System
- Ozone Sanitization System
- In-Line and Friction Heaters
- Bidet Jet System
- Heated Seat & Backrest
- L-Shaped and Straight Shower Rod Kits
- Rain Shower Faucet Package
- Adjustable Handheld Shower Holder
- Tile Flange Kit
- End Panel for the Seat and/or Faucet Side
- Neck Rest Pillow and Seat Cushion
- Bathing Support Harness
- U Safety Grab Bar

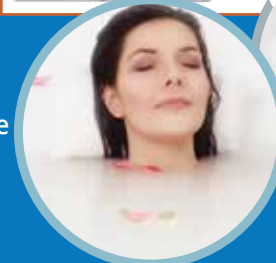

Heated Seat

Microbubble
Skin Therapy System



Plumbing Safety
Certified



Electrical Safety
Certified



Limited Lifetime
Warranty



Expedited Freight Shipping
(less than 2 weeks)



American Tubs

1101 Fullerton Rd. City Of Industry, CA 91748

Tel: 626-581-3588 Fax: 800-943-8652

www.americantubs.com sales@americantubs.com