



EXTRA WIDE AND DEEP SERIES **D3555KS Walk-In Tub**

The American Tubs **D3555KS** from our Extra Wide and Deep Series is a top of the line bariatric walk-in tub that provides fuller-figured individuals up to 450 lbs. a safe and comfortable bathing experience. The D3555KS is, bar none the widest and most spacious walk-in tub model on the market. The convenient, 23 ½", curved doorway makes entry and exit of the tub incredibly easy, while the extra-wide, 27" seat, with an under-seat support frame, provides ample bathing space with some additional "wiggle room". Attention should be paid to both the current size of the hot water heater as well as to the hallways, doorways and stairwells leading up to the bathroom. Having the largest well space of any of the American Tubs walk-in tubs, the D3555KS is a popular choice for multi-generational homes or for individuals who prefer showers.



Therapeutic System Options

- Hydromassage System – 10 Jet
- Air Massage System – 20 Jet
- MicroBubble Skin-Cleansing System

Door/ Drain Orientation

- Left-Hand or Right Hand



Available Colors

- White or Biscuit



Standard Features

- Marine-Grade Fiberglass & Resin Composite Tub Shell
- High-Gloss, Triple-Coated Gelcoat Finish
- One-Piece, Stainless Steel Support Frame
- 6 Adjustable Leveling Legs
- Low, 6" Door Threshold
- Ergonomic Curved Door Handle
- Water-Tight Door Seal
- 17" High, ADA-Compliant, Contoured Seat
- Interior Safety Grab Bar
- Deck-Mounted, U-Shaped Grab Bar
- Non-Slip Textured Floor
- Integrated Door Drain
- 2 Integrated Front Access Maintenance Panels
- Color-Matched Extension Kit to fill 60"
- Flangeless Design

Contact Us Address

1101 Fullerton Rd.
City Of Industry, CA 91748

Phone

Tel: 626-581-3588
Fax: 800-943-8652

Web

www.americantubs.com
sales@americantubs.com

Top View **D3555KS Walk-In Tub** Side View

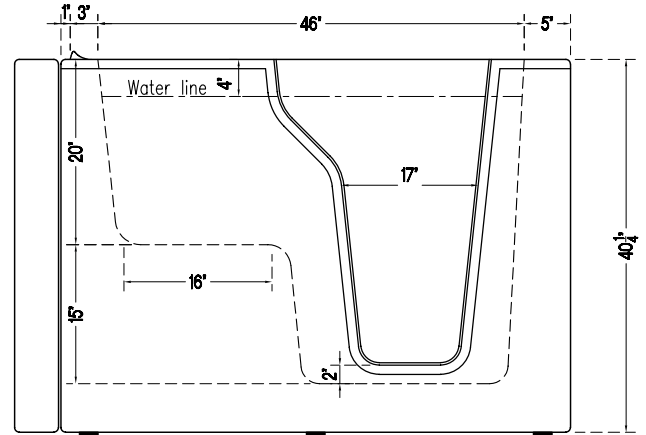
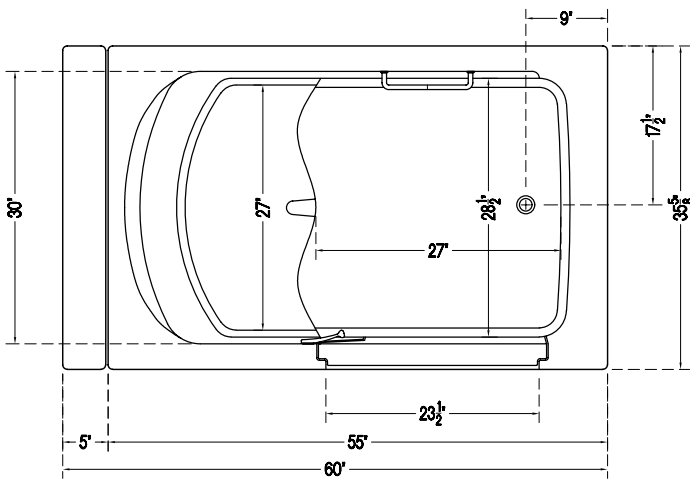

D3555KS SPECIFICATIONS	
Tub Dimensions	35 $\frac{3}{8}$ " W x 55" L x 40 $\frac{1}{4}$ " H
Top Diagonal	65"
Tub Weight	200 lbs.
Crated Dimensions	37" W x 56" L x 51" H
Water Capacity (with user inside approximately)	300 lb. / 72 Gallons 350 lb. / 67 Gallons 400 lb. / 62 Gallons
Seat Dimensions	H: 17"; W: 27"
Door Width	23 $\frac{1}{2}$ " (At Top)
Door Swing	Inward-Swinging

DRAIN OPTIONS	2" Hurry Drain™
	Secondary Emergency Drain
	Power Drain

FAUCET OPTIONS	Elite	4 pcs	Chrome	Modern
	Bellevue	5 pcs	Chrome	Modern
	Bellevue	5 pcs	Satin Nickel	Modern
	Bellevue	5 pcs	Oil-Rubbed Bronze	Modern

Add-Ons And Upgrads

- Hydro Massage System
- Air Massage System
- Micro Bubble System
- Leg Massage Only System
- Chromatherapy Light System
- Aromatherapy System
- Ozone Sanitization System
- Water-Heating Syllent Pump
- Friction Heater
- Inline Heater
- Additional Hip or Knee Jets

Optional Accessories

- Heated Seat & Backrest
- Anti-Scald Valve
- Swinging Glass Shower Door
- L-Shaped Shower Curtain Rod
- Adjustable Shower Slide Bar
- Neck Rest Pillow
- Seat Cushion
- End Panel for Seat and/or Faucet Side
- Optional Tile Flange Kit
- Additional 12" Extension Kit
- Bathing Support Harness



Heated Seat

Microbubble Skin Therapy System



Plumbing Safety Certified



Electrical Safety Certified



Limited Lifetime Warranty



Expedited Freight Shipping (less than 2 weeks)



American Tubs

1101 Fullerton Rd. City Of Industry, CA 91748

Tel: 626-581-3588 Fax: 800-943-8652

www.americantubs.com sales@americantubs.com