



## EXTRA WIDE AND DEEP SERIES **D3355KS Walk-In Tub**

The American Tubs **D3355KS** from our Extra Wide and Deep Series offers a luxury spa experience in the comforts of your own home. The extra wide interior is specially designed to accommodate individuals up to 350 lbs.

The D3355KS is one of the widest and roomiest walk-in tubs on the market, second to our D3355KS model. The curved, 23 ½" doorway design allows for easy entry into the tub's interior even for someone with a large midsection. The extra-large, 25 ½" seat can only be found on the D3355KS walk-in tub, plus the expansive well is perfect for a comfortable standing shower. It's important to note that the D3355KS is best suited for a larger bathroom and often requires doorway widening to get into the bathroom.



### Therapeutic System Options

- Hydromassage System – 10 Jet
- Air Massage System – 20 Jet
- MicroBubble Skin-Cleansing System

### Door/ Drain Orientation

- Left-Hand or Right Hand



### Available Colors

- White or Biscuit



### Standard Features

- Marine-Grade Fiberglass & Resin Composite Tub Shell
- High-Gloss, Triple-Coated Gelcoat Finish
- One-Piece, Stainless Steel Support Frame
- 6 Adjustable Leveling Legs
- Low, 6" Door Threshold
- Ergonomic Curved Door Handle
- Water-Tight Door Seal
- 17" High, ADA-Compliant, Contoured Seat
- Interior Safety Grab Bar
- Deck-Mounted, U-Shaped Grab Bar
- Non-Slip Textured Floor
- Integrated Door Drain
- 2 Integrated Front Access Maintenance Panels
- Color-Matched Extension Kit to fill 60"
- Flangeless Design

### Contact Us Address

1101 Fullerton Rd.  
City Of Industry, CA 91748

### Phone

Tel: 626-581-3588  
Fax: 800-943-8652

### Web

[www.americantubs.com](http://www.americantubs.com)  
[sales@americantubs.com](mailto:sales@americantubs.com)

# D3355KS Walk-In Tub

Top View

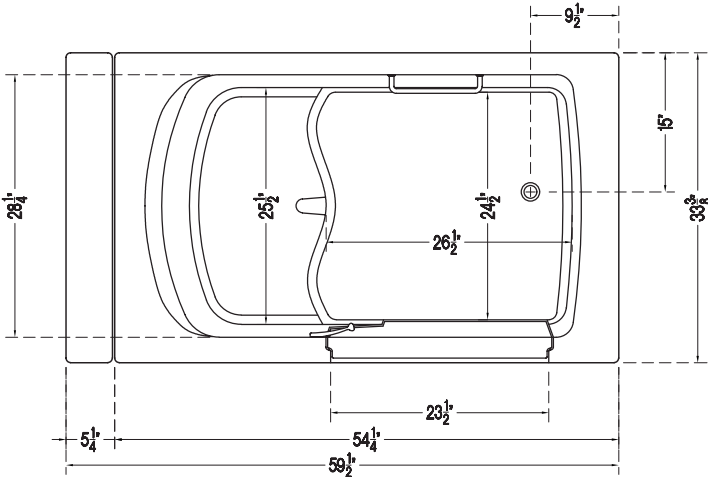

Side View

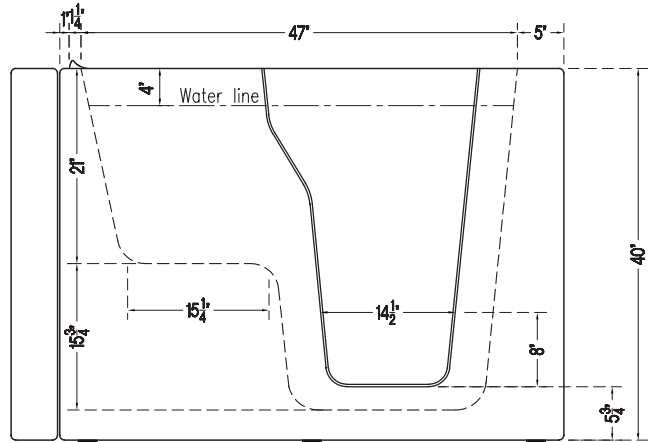

## D3355KS SPECIFICATION

Tub Dimensions	33 <sup>5</sup> / <sub>8</sub> " W x 54 <sup>1</sup> / <sub>4</sub> " L x 40" H
Top Diagonal	63 <sup>3</sup> / <sub>4</sub> "
Tub Weight	169 lbs.
Crated Dimensions	35 <sup>1</sup> / <sub>4</sub> " W x 56" L x 51" H
Water Capacity (with user inside approximately)	250 lb. / 70 Gallons 300 lb. / 67 Gallons 350 lb. / 64 Gallons
Seat Dimensions	H: 17"; W: 25 <sup>1</sup> / <sub>2</sub> "
Door Width	23 <sup>1</sup> / <sub>2</sub> " (At Top)
Door Swing	Inward-Swinging

## DRAIN OPTIONS

2" Hurry Drain™
Secondary Emergency Drain
Power Drain

## FAUCET OPTIONS

Elite	4 pcs	Chrome	Modern
Bellevue	5 pcs	Chrome	Modern
Bellevue	5 pcs	Satin Nickel	Modern
Bellevue	5 pcs	Oil-Rubbed Bronze	Modern

## Add-Ons And Upgrads

- Hydro Massage System
- Air Massage System
- Micro Bubble System
- Leg Massage Only System
- Chromatherapy Light System
- Aromatherapy System
- Ozone Sanitization System
- Water-Heating Syllent Pump
- Friction Heater
- Inline Heater
- Additional Hip or Knee Jets

## Optional Accessories

- Heated Seat & Backrest
- Anti-Scald Valve
- Swinging Glass Shower Door
- L-Shaped Shower Curtain Rod
- Adjustable Shower Slide Bar
- Neck Rest Pillow
- Seat Cushion
- End Panel for Seat and/or Faucet Side
- Optional Tile Flange Kit
- Additional 12" Extension Kit
- Bathing Support Harness

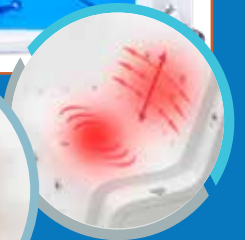
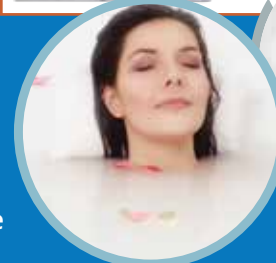

Heated Seat

Microbubble  
Skin Therapy System



Plumbing Safety  
Certified



Electrical Safety  
Certified



Limited Lifetime  
Warranty



Expedited Freight Shipping  
(less than 2 weeks)



## American Tubs

1101 Fullerton Rd. City Of Industry, CA 91748

Tel: 626-581-3588 Fax: 800-943-8652

[www.americantubs.com](http://www.americantubs.com) [sales@americantubs.com](mailto:sales@americantubs.com)